



LIFE
IS IN
SESSION



BUTLER UNIVERSITY





BUTLER UNIVERSITY

LIFE *is in* SESSION

LEARN BETWEEN THE LINES

AS A BUTLER STUDENT, you might wish you had more hours in a day, because Butler offers countless things to do, and Bulldogs want to do it all. Nearly everyone is involved with something outside of class. We seek out new experiences every day by joining clubs, playing on teams, volunteering in the community, and making lifelong friends along the way.

So when you come to Butler, study hard for your classes, but make time for fun, too, because that's one of the best ways to learn. The most powerful skills you acquire in college could come from the most unexpected places.

At Butler, we're learning lessons for life—and class is in session.

★★ LIFE *is in* SESSION ★★

MAKE YOUR

NEXT FOUR

YEARS



YOUR

BEST FOUR

YEARS





LIVING ON CAMPUS

Moving into your first place away from home is liberating and exciting. And at Butler, you'll share this experience with new roommates and neighbors—all part of a campus community that makes residence halls feel more like homes. Some of your best relationships will begin right here. Most first-years, sophomores, and juniors live on campus. You'll never be far from anything you need—your classes, the library, the Rec Complex, and late-night snacks are just a short walk away.

CAMPUS DINING

It's hard to miss home-cooked meals when you have them right here at Butler. Grab a bite to eat with your friends at one of the many dining locations, like the C-Club Food Court or Atherton Marketplace. And if you're looking for a quick pick-me-up, head to the campus Starbucks for some coffee. You can choose whatever meal plan and flex dollars work best with your schedule and enjoy full access to a wide variety of delicious, fresh-made foods and snacks to help you power through the day.

HEALTH AND RECREATION

It's easy to stay active at Butler because right next to Hinkle Fieldhouse is the

state-of-the-art Health and Recreation Complex (HRC). Inside is everything you could ask for—basketball courts, a six-lane swimming pool, group fitness classes, an elevated indoor track, three fitness floors, and more. Students receive full membership to the HRC, so you'll be able to head in and break a sweat any time you want.

BUTLER RESIDENCE HOUSING

Ross Hall*, Residential College*, Apartment Village, University Terrace, Butler Terrace, and Fairview House (opened fall 2016)

**First-year housing*

★ THEMED LIVING COMMUNITIES ★

At Butler, our first-year students belong to Themed Living Communities (TLCs). In a TLC, students have the opportunity to make friends and engage with others. Students will explore common interests, often in the context of the larger campus and/or Indianapolis community. By living in a TLC, students are able to make connections with others, embrace a sense of common community, and start building connections that will continue throughout their time at Butler.

EXPLORE
YOUR
PASSIONS.
FIND YOUR
PURPOSE.

★★ LIFE is in SESSION ★★

EACH WEEK, buses of local elementary-school children arrive at Butler, eager to meet with their mentors and learn about life on a college campus. It's part of the College Mentors for Kids service organization, where Butler students each mentor several children and share their learning experiences. It's a great way to have fun and make a difference in the lives of others.

Whatever your interests—volunteering, rock climbing, fashion design, Asian culture, dance—there's probably a club for it at Butler. We have over 150 student organizations, intramural and club sports, and volunteer opportunities year-round. And if you don't find the organization you're looking for, you can make your own.

Nearly everyone you meet at Butler is involved with something outside of class. Because for us, taking part in new and unique experiences isn't a choice—it's a way of life.

BUTLER'S WOMEN'S CLUB VOLLEYBALL TEAM WON THE 2015 COLLEGIATE VOLLEYBALL FEDERATION NATIONAL CHAMPIONSHIP. CLUB VOLLEYBALL IS ONE OF 18 CLUB SPORTS TEAMS.





GREEK LIFE

BULLDOGS, START YOUR CHARIOTS

AS YOU MOUNT YOUR TWO-WHEELED CHARIOT, you can feel your opponents' presence next to you on the starting line. The arena is filling with spectators cheering loudly, chanting a familiar battle cry. But you're only focused on one thing—winning. The trumpets sound, the flags are waved, and you're jolted ahead in a flash.

No, this isn't Ancient Rome.
It's Hampton Drive.

Every Homecoming Weekend, hundreds of Butler students and alumni gather to watch fraternities compete in the high-stakes Chariot Races. It's one of Butler's oldest traditions, dating back to the 1950s, and just one of the many Greek life events happening all year round.

Greek organizations at Butler use deferred recruitment, which gives you time to explore all of the organizations to find the one that's right for you. Starting spring semester of your first year, you have the option of joining one of the seven sororities or five fraternities on campus. It's a great way to meet new people, build lasting relationships, develop leadership skills, and participate in philanthropic, academic, and social activities.





BUTLER HAS BEEN AFFILIATED WITH **NINE** HISTORICALLY BLACK FRATERNITIES AND SORORITIES SINCE 1922.

36%

OF BUTLER STUDENTS GO GREEK.

ATHLETICS

WE

PLAY

OUR

WAY.

THE BUTLER WAY.

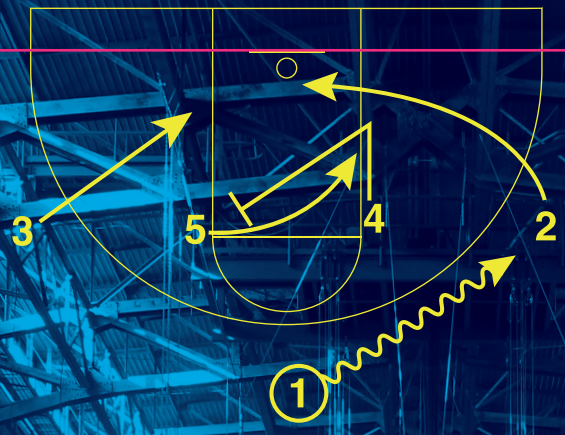

BULLDOGS

HINKLE FIELDHOUSE

8

6

HINKLE FIELDHOUSE



YOU'RE CHEERING LOUD FOR THE BULLDOGS, thousands of eyes are glued to a single ball, and you watch Butler sink a winning shot in the last minute of a game.

It's a surreal experience, being surrounded by your classmates decked head-to-toe in Butler blue, witnessing a historic victory unfold. And next year, you could be part of it.

What really makes the Dawgs great isn't our two national championship runs, historic Hinkle Fieldhouse, or the BIG EAST Conference. It's how we play—*The Butler Way*. It means we always put team above self. It means working hard in the classroom and in the gym, even when no one's watching. It keeps us in the game (even when we're dog-tired) and passing to the open man rather than taking a contested shot on our own.

Across every sport, we let our games do our talking—and the way we play speaks volumes.

VARSITY SPORTS

MEN'S

- Baseball
- Basketball
- Cross Country
- Football*
- Golf
- Soccer
- Tennis
- Track and Field

WOMEN'S

- Basketball
- Cross Country
- Golf
- Lacrosse
- Soccer
- Softball
- Swimming
- Tennis
- Track and Field
- Volleyball

*Pioneer Football League





ARTS AND CULTURE

BREAK FROM THE ORDINARY— SEE THE EXTRAORDINARY

Thousands of immaculate brushstrokes forming a painting, the delicate wave of a ballerina's arm, an entire choir singing in harmony—these are the kinds of artistic expression that can enlighten us, inspire us, and move us to tears.

There's a whole world of art to discover at Butler. Located in the heart of campus is Clowes Memorial Hall—one of the largest and most versatile performing arts venues in the city of Indianapolis. Butler ArtsFest, a two-week-long festival featuring more than 30 performances presented by Butler students and performing artists from around the world, occurs on campus each spring.

At Butler, you can see Broadway shows; popular touring artists; Butler Ballet, Theatre, and School of Music productions; art exhibitions; or a speech by a Nobel Prize winner. Throughout the year, there's always something to entertain, engage, and inspire you.

Around Indy, you'll find a flourishing culture of theaters, museums, galleries, and festivals. Try an unfamiliar cuisine at a restaurant in neighboring Broad Ripple Village, check out a foreign film, or see a standup comedian. Whatever you're searching for, you'll find a city that opens your mind, sparks your imagination, and inspires creativity.

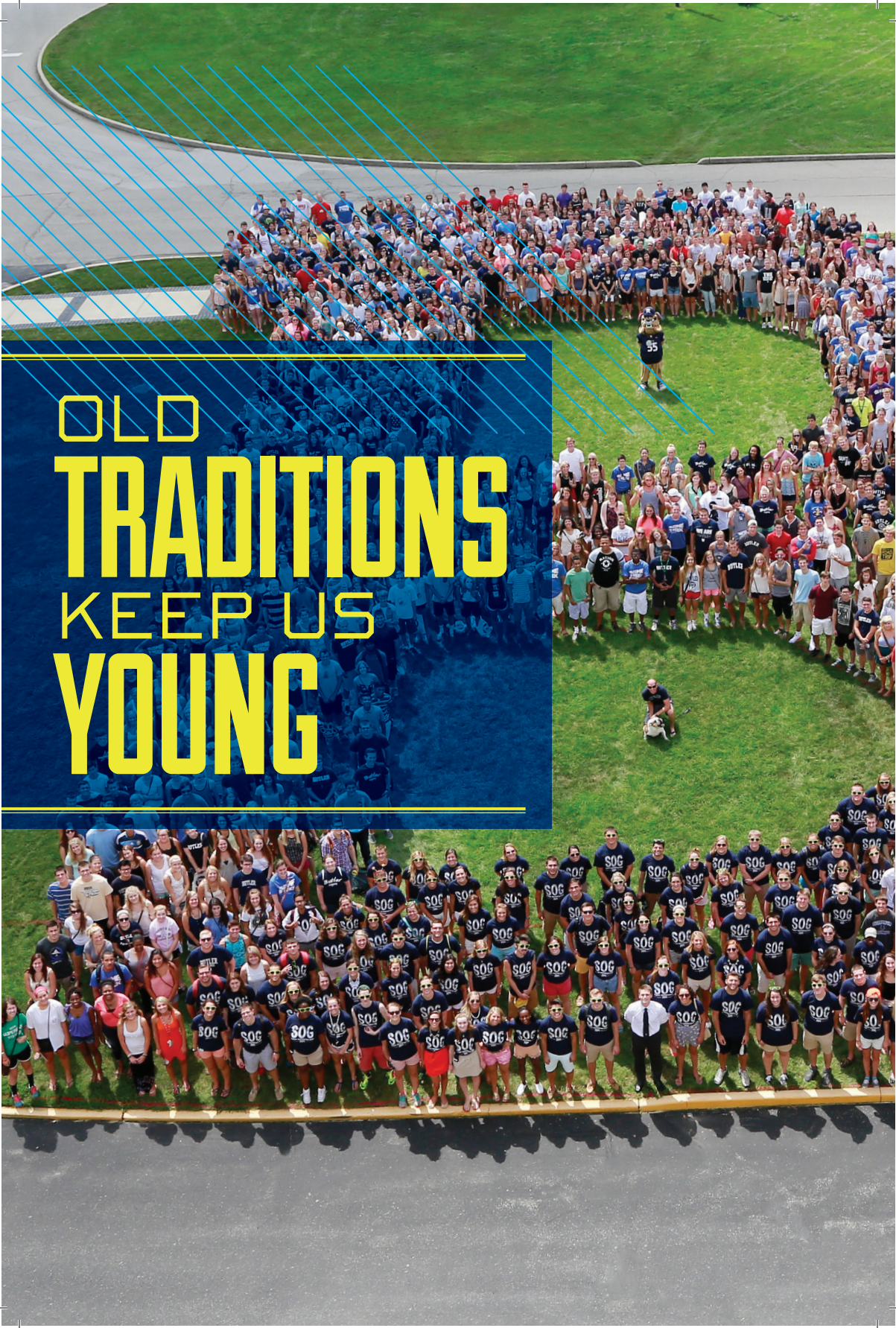

OLD
TRADITIONS
KEEP US
YOUNG



CAMPUS TRADITIONS

EVERY YEAR, FIRST-YEAR BUTLER STUDENTS find themselves dressed in costume, singing and dancing for the whole University in Hinkle Fieldhouse. It's part of First-Year Skits—a yearly competition between the new member classes of the Greek houses on campus. The show, hosted by the Blue Key Honor Society, helps raise money for Butler philanthropic groups like Help Heal Haiti and Wish Makers.

First-Year Skits is just one of many traditions at Butler, some of which have been around for nearly 100 years. How have they lasted so long? Why don't you ask the students who are racing down the street in handmade chariots, playing games until the wee hours of the morning at the Spring Sports Spectacular, or canoeing, spelunking, and zip-lining at the Wilderness Explorers pre-orientation week. Traditions are what make Butler fun, and they aren't going anywhere.

WELCOME WEEK

You could spend your first week at Butler meeting new friends, connecting with faculty and staff, learning about campus resources, exploring student organizations, and taking part in tons of other fun events, including a performance by the "Most Popular College Hypnotist," Dr. Jim Wand.



INDIANAPOLIS

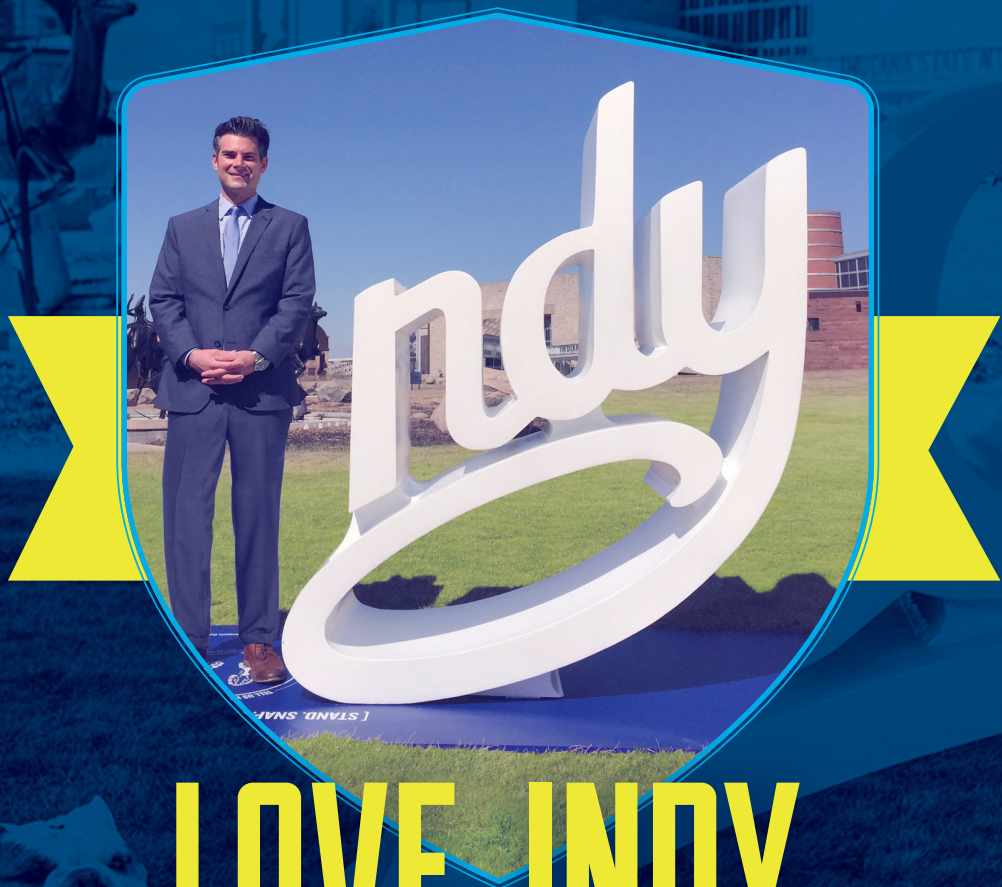

LOVE. INDY.



“I” AM IN
[STAND, SNAP, SHARE, #LO

Chris Gahl '00, Vice President of
Marketing and Communications, Visit Indy

THERE'S NO SHORTAGE of fun in Indy. Art festivals, Colts games, outdoor concerts, the Indianapolis 500—these could all be part of your college experience at Butler. We're a short drive from Eagle Creek Park's 4,000 acres of trails and ponds for running, biking, or canoeing. And we're just five miles north of downtown, with easy access to public transportation that will help you get around the bustling heart of the 14th-largest city in the country.

Indianapolis also allows you to have more exciting jobs, internships, and service-learning experiences than you might find elsewhere. Recently ranked second by Trulia and LinkedIn for jobs available for recent grads, Indy is filled with businesses, organizations, and Fortune 500 companies that will help you advance your career and get involved.

Butler and Indianapolis are truly connected, and being a Bulldog means you're part of this thriving, inspiring, and well-connected community.

SHARE YOUR STORY

When you come to Butler, you may spot “#LoveIndy” signs around the city. They're all part of a photo story series showcasing the people who make Indianapolis a lovable city. The project began with Butler alumna Camryn Walton '14, who amplified her love for Indianapolis with an internship at Visit Indy, where she successfully pitched the idea.

“My number-one goal of Love Indy is to empower each and every person who lives, works, and plays in Indianapolis to be an Indy ambassador,” said Camryn, “by engaging in genuine conversations, connecting with their neighbors, experiencing Indy in new ways, and growing the love we have for this city.”

Join the conversation at **#LOVEINDY**.



INVEST *in* YOURSELF

YOUR COLLEGE DEGREE IS MORE THAN A PIECE OF PAPER

to frame and hang in an office. It's a collection of experiences, memories, and relationships you build over several years.

At Butler, you'll learn plenty from your classes and your books, but it's the things you *do* along the way that matter most. It's your *experiences* that will open doors for your career, your *friends* who will make the journey worthwhile, and your *memories* that will bring you happiness for a lifetime. That's what makes Butler a priceless investment

FINANCIAL AID

If you have the drive and the desire to study at Butler University, we're dedicated to helping you and your family make the investment. There are options for grants and scholarships to assist with finances, and our financial aid counselors are here to help. Learn more at butler.edu/financial-aid.

TUITION AND FEES

DIRECT COSTS 2016-2017

TUITION	\$37,400
ROOM & BOARD	\$12,670
FEES	\$960

INDIRECT (EST.) COSTS 2016-2017

BOOKS	\$1,000
TRANSPORTATION	\$900
MISC. EXPENSES	\$1,650

TOTAL COST OF

EDUCATION	\$54,580
-----------------	----------

93 % of Butler students received gift aid in 2015.

To learn about your Butler investment, visit butler.edu/invest.



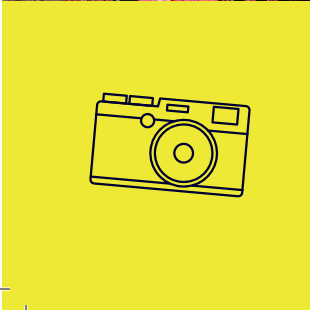
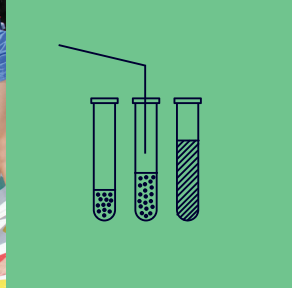
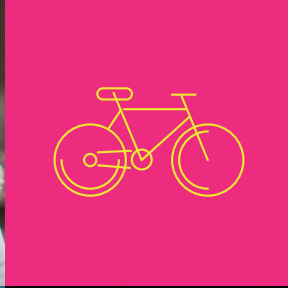
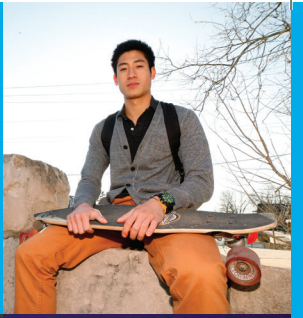
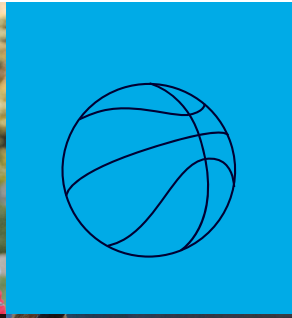

EXCITING

TIMES

AHEAD

WHEREVER YOU DECIDE TO ATTEND COLLEGE, this time is just the beginning of your journey as an adult, so make it count.

Ask any Bulldog and they'll tell you that joining the Butler community started one of the best chapters of their life. That's because at Butler, you're preparing for your future by experiencing life to the fullest—joining clubs, playing sports, completing internships, volunteering in your city, and making new friends.

It's your time to expand your positive influence on the world and develop the skills you need for a happy and successful life. *Butler University is waiting for you.*

★★ LIFE *is in* SESSION ★★



SEE FOR YOURSELF.

THE BEST WAY to get a feel for life at Butler is to experience it firsthand. Take a group tour of campus. Meet current students. Watch the Bulldogs compete at Hinkle Fieldhouse or the Butler Bowl. And definitely make time to explore the city of Indianapolis. Head to butler.edu/admission to meet your admission counselor and schedule your visit.

BUTLER UNIVERSITY

Office of Admission

888-940-8100

admission@butler.edu

butler.edu/admission

 [@gobutleru](https://twitter.com/gobutleru)

 [@butleru](https://www.instagram.com/butleru)

APPLY NOW!
WE THINK YOU'D MAKE
A GREAT BULLDOG.
BUTLER.EDU/APPLY

Butler University admits students without regard to their race, color, sex, age, national or ethnic origin, religion, sexual orientation, ancestry, military discharge or status, marital status, parental status, or any other protected status. Otherwise qualified persons are not subject to discrimination on the basis of disability.

READY TO APPLY?

There's never been a better time to be a Butler Bulldog.

HERE ARE A FEW THINGS YOU'LL WANT TO GET TOGETHER FIRST:

REQUIRED

- › Butler Application or Common Application
- › Writing sample, personal statement, or essay (*500 words or less*)
- › Official SAT and/or ACT scores
Butler accepts both the Pre-March-2016 SAT and the new SAT
- › Official high school transcript showing coursework completed through your junior year
- › A Secondary School Report completed by your guidance office

OPTIONAL

- › Résumé outlining activities and honors
- › Letter(s) of recommendation (1-2)

KEY DATES

AUG

August 1: Application opens

OCT-DEC

Late October–Mid-December:

Early Action admission decisions released

NOV

November 1: Early Action Deadline

Early Action benefits include full academic scholarship consideration and honors program eligibility.

DEC

December 1: Recommended FAFSA Filing Date

MID-JAN

Mid-January: Financial aid notification begins

FEB

February 1: Regular Decision Deadline

MAR

March 1: Butler FAFSA Deadline

MAY

May 1: National Candidate's Reply Date
A \$500 enrollment deposit is due to the Office of Admission. This deposit is refundable through May 1.





BUTLER
UNIVERSITY

4600 Sunset Avenue, Indianapolis, IN 46208

butler.edu/admission

#butlerbound

A series of thin, parallel diagonal lines in a light blue color, located at the bottom right corner of the page, extending from the center towards the bottom right edge.